

Reverse Dial Indicator Alignment

RDIA

Mis-alignment can be the most usual cause for unacceptable operation and high vibration levels. New facilities or new equipment installations are often plagued by improper alignment conditions.

Many methods are used to align machinery. The simplest method is using a straight edge to bring the machines into rough alignment. A rough alignment is necessary due to the range limitations of the dial indicators. A popular method used for years and is still in use today is the rim and face method. This method produces acceptable results, but is less accurate than the reverse dial indicator method covered in this application note. Additionally, reverse dial alignment does not require removal of the coupling to collect data.

Working With Dial Indicators

1 Full Revolution = 100 Mills

Each Division = 1Mil
1 Mil = 0.001"
0.001" = 1/1,000"

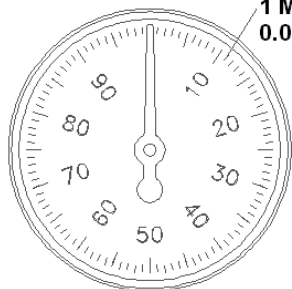

Graduation = 0.001" Range = 0.200"

Dial indicators are available in many physical sizes and ranges. For most alignment applications the smaller sized indicators should be used to reduce indicator bar sag. Dial indicators should be chosen that have a range of 0.100 inch and accurate to 0.001 inch.

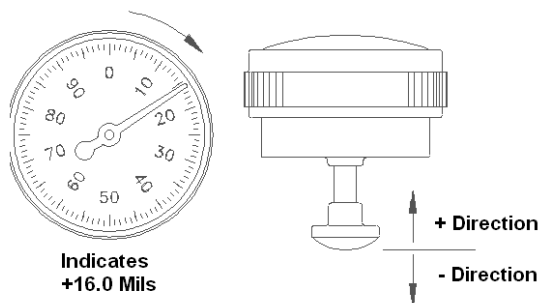

Indicator readings, and many other types of readings, are expressed in several units. A reading of 1/1000" is equivalent to 0.001 inch and is commonly expressed as 1 mil.

A common convention used when reading dial indicators is that when the indicator plunger is moved toward the indicator face the display show a positive (+) movement of the dial needle by sweeping the needle clockwise. As the plunger is stroked away from the face a negative (-) reading is displayed by sweeping the needle counterclockwise. Negative movements of the dial needle may be confusing if the indicator is not observed carefully throughout the rotation cycle of the machine shafts.

Another convention to employ is that when all readings are recorded, they should be interpreted recorded by viewing from the stationary machine to the moveable machine. This convention is necessary to distinguish right from left readings during data collection process and will be applied when the calculations and graphs are made to decide upon the actual moves required at the moveable machine.

Pre-Alignment Conditions

Prior to any alignment activity an extensive list of items must be checked to ensure acceptable results. The obvious item involves ensuring that the machine shaft axes are roughly aligned within 50 mils. Other inspections should include:

1. The foundation base plate is adequate and that grout has been installed properly.
2. All machine feet are in full contact with the foundation base plate or supports.
3. Piping is not inducing strain onto the machine cases. Piping should be aligned to within $\frac{1}{8}$ " of their flanges.
4. The machine feet bolt-holes have enough clearance to conduct alignment activity.
5. The coupling faces are axially aligned; the axial spacing between the coupling faces as correct.
6. Coupling radial runout is less than 2 mils.
7. Coupling face runout is less than $\frac{1}{2}$ mil.
8. The moveable machine has an initial shim pack installed; the shim pack should be comprised of one thick spacer and one or two smaller shims. Too many shims will act like a spring causing additional problems.
9. The required amount of cold offset compensation is available; this may be available from the machine manufacturer.
10. The alignment bracketry is appropriate to the

Reverse Dial Indicator Alignment

RDIA

MOUNTING DIAL INDICATORS

Many commercially available reverse dial indicator alignment kits have modular bracketry, which can encompass the majority of applications. However, some applications will require a custom bracket. Regardless of the type of bracket used, the amount of bracket or bar sag should be documented so that this information is available to be included in the calculations.

Verify and Document Bar Sag!

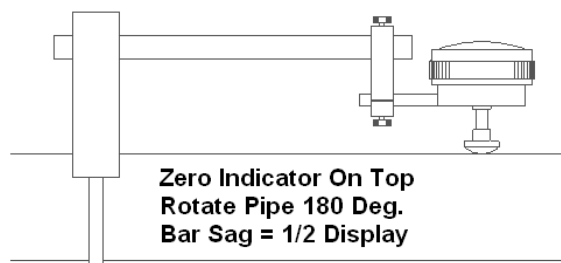

Bar sag can be easily documented by installing the bracket and dial indicator, in the identical arrangement to be used on the machine, onto a pipe. Zero the indicator while it is on top of the pipe. Now rotate the pipe 180° so that the indicator is at the bottom position. The indicator will now display twice the amount of bar sag.

Mounting the indicator onto the bracketry should be performed carefully so that the indicator plunger axis is perpendicular to the machine shaft axis to ensure accurate readings. An error of only 10° will produce a 16% error in the indicator reading.

TAKING READINGS

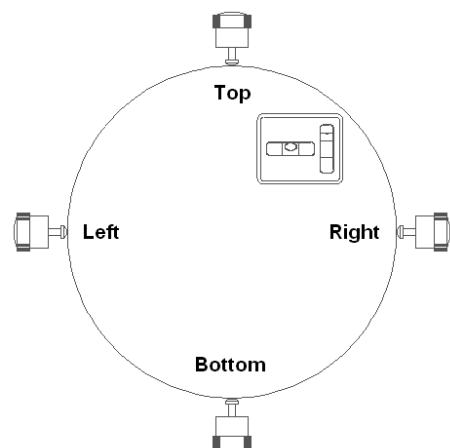

After the bracketry is firmly attached and the dial indicators are installed, four reading locations are required. These locations are along the circumference of the shaft or coupling in the path of the indicator plunger. They are top, bottom, right, and left. These locations are to be separated by 90° of shaft rotation. Marking these locations with an indelible marking pen is adequate. Another approach is to use a common two-axis trailer level attached to a coupling face or other surface to determine when the shaft has been rotated 90°. Placing four pieces of tape equally spaced around the circumference of the shaft will work, as long as the tape is not in the path of the indicator plunger.

Before any readings can be taken the dial indicators must be set. A simple test of rotating the machine shaft through an entire 360° sweep will verify that the indicator plunger tip is in complete contact with the shaft. When the indicator is at the top location the indicator should be reset to display zero. This is accomplished by rotating the outer bezel of the indicator until the dial face, which is attached to the bezel, shows "0" under the needle.

Collecting the data is simply a matter of rotating the machine shaft in 90° increments and noting the dial indicator readings with their signs (+ or -).

If only one dial indicator setup is available, the bracketry must be relocated to the other coupling or shaft and the sweep should be repeated. Remember, that all readings should be collected while observing from the stationary machine to the moveable machine to maintain right and left consistency.

Reverse Dial Indicator Alignment

RDIA

ACCURACY VERIFICATION

Collecting the necessary data is simple enough, but will be entirely useless without some form of accuracy verification. Each time the dial indicator is rotated to the top location it should display a reading of zero. If it does not then something has moved during the rotation: indicator, bracket, clamping mechanism, machine. Correct the problem and start over.

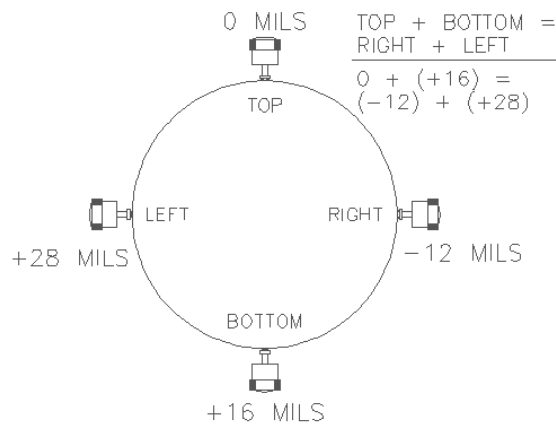

Another test, which can be performed as the data is collected, is to verify that the sum of the top and the bottom readings should equal the sum of the left and right readings.

CALCULATIONS

As the dial indicator is swept around the circumference of a coupling or shaft it displays twice the difference between the projected centerline of the indicator's attachment point and the measured shaft centerline. This argument applies for both the vertical and horizontal readings.

Thus, the sum of the vertical and horizontal readings must be divided by two to represent the actual differences in the two shaft centerlines. Remember to observe the signs of the indicator readings closely to prevent errors in these calculations.

Two vertical offset numbers and two horizontal offset numbers will be obtained; one set representing the readings while the bracketry is installed on the original shaft and another set representing the readings while the bracketry is installed on the second shaft.

Horizontal calculations sometimes present some confusion because one side does not start at zero. Adding or subtracting the magnitude of the right side reading to both sides will force the right side to zero.

GRAPHING THE RESULTS

Presenting the calculated results in a graphical format will assist in visualizing the required machine moves. Although any size graph scale is adequate for this process, expanding the scale as large as possible will improve the accuracy of the move calculations because the measured differences of the shaft or coupling centerlines are projected out to the locations of the moveable machine's feet.

As the figure shows, two sets of dial indicator readings are collected. The readings taken on the stationary coupling are located above the stationary machine (pump) and the readings collected on the moveable coupling are located above the moveable machine (motor). When plotting these readings start with the stationary readings and then proceed to plot the moveable readings.

Directly plotting the measured readings will display a representation of the existing mis-alignment. The desired alignment condition can be drawn onto the graph. The desired condition should include any offset compensation so that when the machine train is operating under normal conditions the alignment is within acceptable tolerances.

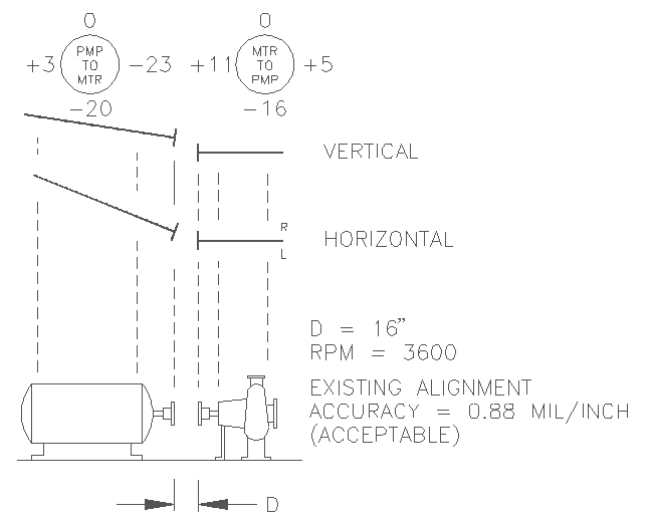

Reverse Dial Indicator Alignment

RDIA

Choose a graph scale large enough to provide sufficient accuracy when all calculations are completed. Lay out the physical dimensions of the machine train and show the collected data on the graph for completeness.

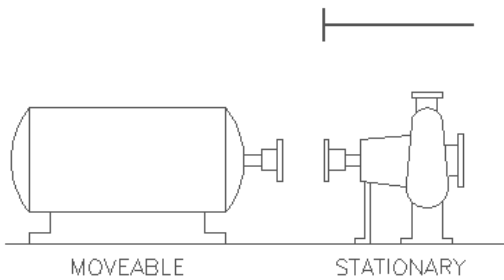
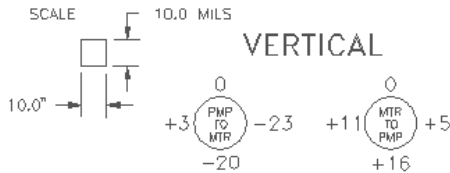

On the graph show the locations of the machine feet, the dial indicator sweep plane, and the location of the power transmission points. Note that for this example, the power transmission points do not coincide with the sweep path of the dial indicators.

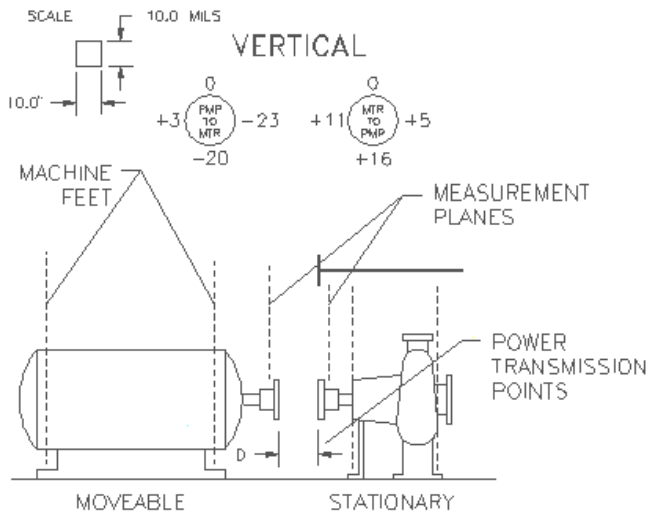

When actually plotting the vertical offsets, start with the stationary set first. Remember that the data collected represents twice the actual differences between the shaft centerlines. A positive result is plotted above the line representing the stationary machine centerline. When plotting the moveable machine readings a rule of thumb is that opposite signs are plotted on the same side of the stationary machine centerline on the graph.

For simplicity's sake, the horizontal readings are plotted separately in this example. A better approach is to combine the vertical and horizontal plots onto a single plot.

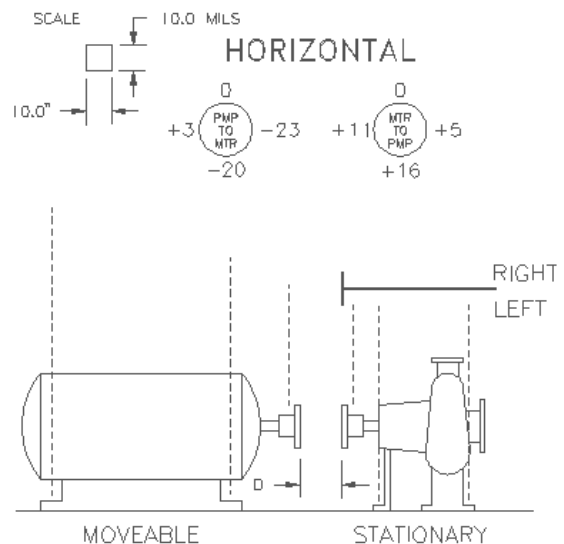
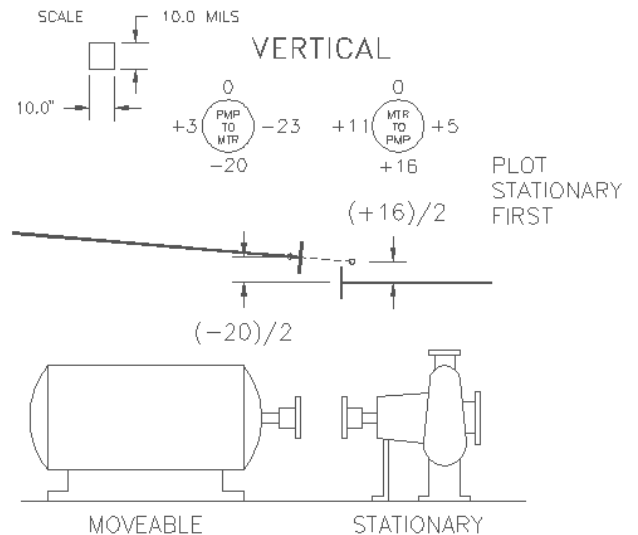

Reverse Dial Indicator Alignment

RDIA

Just as was performed for the vertical plots, the horizontal plot has a scale reference, the field collected data, and other important dimensions shown for completeness. Also, note that the stationary machine centerline is labeled right and left.

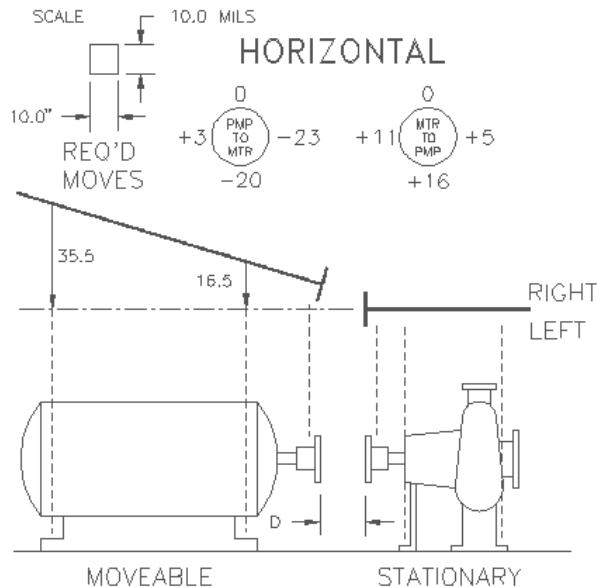

The same process of plotting the data is followed, but note that the field collected data has been adjusted so that the right side readings have a magnitude of zero to make plotting easier. The opposite sign rule of thumb also applies for horizontal plotting.

After all the data has been plotted, the required corrections of the moveable machine can be obtained directly from the graph. Obtaining this information in this manner eliminates mathematical errors possible using other methods. Graphical presentations allow experimentation and study of many possibilities for correcting alignment.

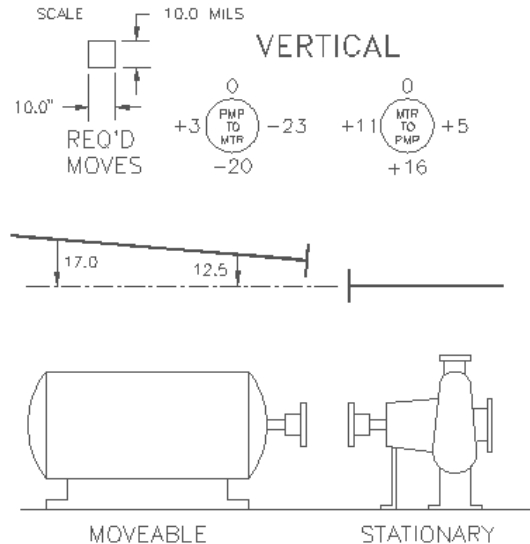

For this example, the motor outboard feet need to be lowered 17 mils and the inboard feet must be lowered 12.5 mils for a perfect alignment with the pump.

This alignment condition assumes that the pump does not thermally grow as it operates. If some thermal growth is anticipated, then this information can be plotted on the graph as an offset of the stationary machine's centerline and appropriate moves of the moveable machine can be obtained by projecting the stationary machine's centerline over to the moveable machine's location.

The horizontal movements for this example are 35.5 mils to the left at the motor outboard and 16.5 mils to the left at the inboard motor feet.

Graphically plotting the results makes the movement computations easier, but prior to any moves the following topic "ACCEPTANCE TOLERANCE" should be considered because the existing alignment may be acceptable. Re-alignment of a machine with acceptable alignment conditions is a waste of time and is only a practice exercise at best that may produce a worse alignment condition.

Reverse Dial Indicator Alignment

RDIA

ACCEPTANCE TOLERANCE

Determining whether the existing alignment condition is acceptable or the actual machine moves resulted in an acceptable alignment condition can be quantified by referencing the chart at the end of this application note. This chart may be applied to all machine and coupling types. The chart takes into account the coupling span and the machine operating speed.

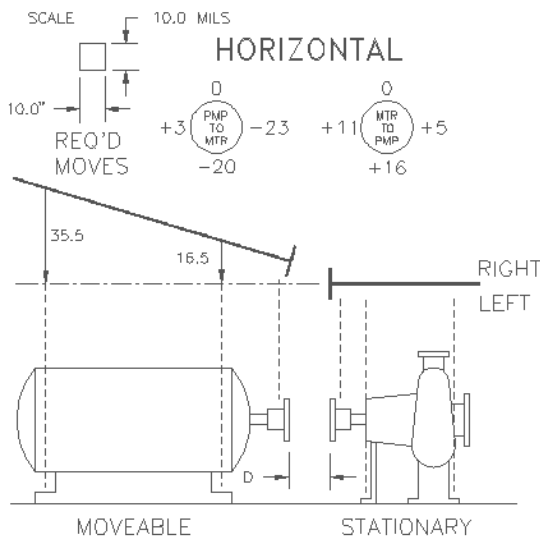

The key to applying the chart is to determine the locations at which the power is transmitted. For gear type couplings the power transmission points are the gear teeth on each coupling half. For diaphragm type couplings the power transmission points are the coupling faces.

The locations of the power transmission points should be noted on the graphical plot. Depending upon the data collection method and the coupling type, the power transmission points may not coincide with the coupling faces or the dial indicator sweep path. Following are the calculations necessary to determine the alignment accuracy:

Alignment Accuracy = Maximum (X, Y)/D where:

$$X = (XV^2 + XH^2)^{1/2}$$

$$Y = (YV^2 + YH^2)^{1/2}$$

XV and XH = amount of offset, vertically and horizontally, at the power transmission point on the stationary machine.

YV and YH = amount of offset, vertically and horizontally, at the power transmission point on the moveable machine.

Maximum (X, Y) = larger of X or Y, calculated above.

Plotting the resultant alignment accuracy on the chart will determine whether the existing alignment condition is acceptable or whether the proposed correction moves will produce acceptable results.

MOVING THE MACHINE

Moving a machine is, in many cases, difficult due to their size and weight. Extremely heavy machines, such as power plant generators will require hydraulic jacks. Most other machines can be moved using jacking screws, which are rigidly attached to the foundation base plate, and pry bars to lift the machine.

Prior to any horizontal move a dial indicator should be installed to monitor each foot along one side of the machine for horizontal movements. Vertical movements will require an indicator on each foot on both sides of the machine. Vertically oriented indicators should be observed as the machine foot bolts are re-torqued. The displayed indication should not change by more than 1-2 mils, indicating that all feet are supporting the machine equally. Finally, after the bolts are re-torqued the jacking bolts should be backed out so that they do not influence the natural thermal growth as the machine heats. Other machines, such as gear boxes, turbines, and compressors should have dowel pins installed at strategic locations to control the thermal growth direction.

The best choice for shim material is stainless steel. This material is very stable and is easy to maintain. Carbon steels should be avoided because it will rust and eventually compromise the machinery alignment. Synthetic or plastic shim material should be avoided for industrial applications because it is easily damaged and under heavy load will deform which

Reverse Dial Indicator Alignment

RDIA

The shims used for industrial applications should be large enough to adequately support each foot. Commercial shims are available in various dimensions. These shims are pre-cut and dimensioned to standard thicknesses which are labeled on a small tab. These shims are easy to install and are difficult to mix up. If shims are manufactured in the field they should be large enough to support the machine foot and all edges should be smoothed to eliminate burrs. Kinked or otherwise damaged shims should be discarded and new ones obtained. The shims, the base plate surface, and bottoms of the machine feet should be clean and free of defects prior to installing any shims.

WHICH MACHINE MOVES?

Generally, the stationary machine has certain constraints which make it impractical to move it. Pumps have rigid piping attached, generators have complex cooling systems, and gear boxes are relatively sensitive to any orientation other than flat and level. When these machine types are moved the attached systems must be relocated to eliminate sources of strain.

Multiple case machine trains, such as dual compressors driven by one turbine, pose another problem. All three machine shafts must operate co-linearly to function efficiently. By studying the graphical plot of the current alignment and the desired alignment it may prove most effective to move the center machine case, instead of moving two or three machines.

Alignment Checklist:

1. Pre-alignment Conditions
2. Shim Materials
3. Indicator Bracket Sag
4. Graph Materials

