

## Reciprocating Compressors

Recip

Reciprocating Compressors are utilized in all manufacturing industries. Because these machines are capable of providing high pressure along with variable loading, they are favored for many gas process applications. The total quantity of positive displacement reciprocating engines, pumps and compressors far exceed the number of centrifugal units.

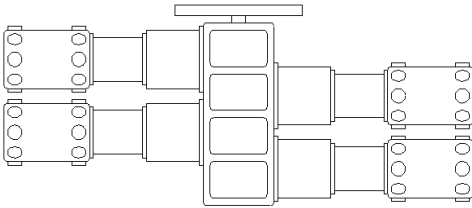

HORIZONTALLY OPPOSED  
RECIPROCATING COMPRESSOR

Past studies within the Hydrocarbon Processing Industry (HPI) indicate that the maintenance costs for reciprocating equipment are approximately 3.5 times that of centrifugal equipment. Substantial savings in maintenance costs and an increase in run time may be achieved through basic monitoring of some if not all of the following Reciprocating Machine parameters.

1. Frame Vibration
2. Rod Drop
3. Rod Run-out
4. Crosshead Vibration
5. Main Bearing Vibration
6. Valve Temperature

### Frame Vibration

The most important vibration parameter of a successful monitoring program is Frame Vibration. When properly applied, monitoring Frame Vibration will help prevent catastrophic failures. In the event of a failure, the damage to a reciprocating machine can be reduced.

For the greatest benefit, a Frame Vibration Monitoring system should be wired to an automatic machine trip. To decrease the possibility of a false trip, two (2) case mounted accelerometers should be mounted on the frame relatively close to each other. The outputs from the two transducers are signal conditioned, and their trip circuits are "AND" voted. In other words, before a trip is initiated, both of the transducers with their monitors must sense a high vibration level.

The 786A Industrial Accelerometer is highly recommended for this application. It's low frequency response of .8 Hz, a standard scale factor output of 100 mV/g, and relative low cost are desired features for this application. Since this transducer is Piezoelectric (Solid State Design) based, it is less susceptible to cross axis signal distortion and wear commonly a problem with other Velocity Transducers.

The two transducers should be perpendicular to the shaft, and oriented in the direction of the Piston travel. The transducers must be mounted on a surface that allows direct transmission of the Frame's Vibration. The transducers must be mounted on a surface that allows direct transmission of the Frames Vibration. Avoid mounting the transducers on a cover or door.

The 786A Industrial Accelerometer should be interfaced to a CMCP530A Velocity Monitor. This combination offers numerous advantages over an OEM supplied "EARTHQUAKE" Switch.

1. Low Frequency Response
2. Solid State Design (Long Life)
3. Indication of Vibration Levels
4. Warning and Shutdown Alarms
5. Shutdown "AND" Voting
6. Fault Detection
7. Vibration Diagnostic Capability

Monitoring the Frame Vibration of a Reciprocating Machine offers the following major benefits:

1. Prevent Catastrophic Machine Failures
2. Reduction of Machine Damage

### Rod Drop

The vast majority of Reciprocating Compressors are designed with horizontal Cylinders and Pistons. This is primarily due to foundation requirements and the popularity of opposed-balanced machine designs.

The force of gravity causes the Piston to "RIDE" more in the bottom of the Cylinder than in the top. In turn, this causes the Piston to wear more in the "DOWN" direction. Machine manufactures provide wear or rider rings to provide a replaceable wearing surface. For lubricated Cylinders, glass embedded Teflon may be used. For non-lubricated Cylinders, Teflon may be used.

The wear or rider rings are allowed to wear sacrificially. They are rotated or replaced before damage to the Cylinder lining occurs. There are several methods used to determine when to replace or rotate the rings. One method is to operate a new machine for a given number of hours or days. Then a valve is removed, and the wear is measured by using a feeler gauge. A calculation is then performed with this information. The results determine the length of time the machine can be safely operated with periodic inspections of the rings. Obviously, this is a very frustrating method of performing preventative maintenance.

Currently, one popular safety device for detecting Rod Drop is a unit mounted under the rod at a gap determined by the allowable wear of the wear ring. When the rod contacts the safety unit white metal is worn through allowing instrument air to escape. This in turn causes a pneumatic flag on the control panel to change status.

There are several disadvantages to the above-mentioned methods of Rod Drop detection:

1. A real trend of ring wear cannot be established with a short amount of operating time.
2. Since the machine must be shut down, halting production, periodic inspections for ring wear are expensive.
3. A change in processed gas, load changes, and foreign matter can cause an extreme change in ring wear rate.

For several years, Eddy Probe systems have been utilized to measure Rod Drop. This method of Rod Drop measurement has been gaining positive recognition with Reciprocating Machine users. This is especially true on larger machines, or when the customer has become frustrated with the previously mentioned methods.

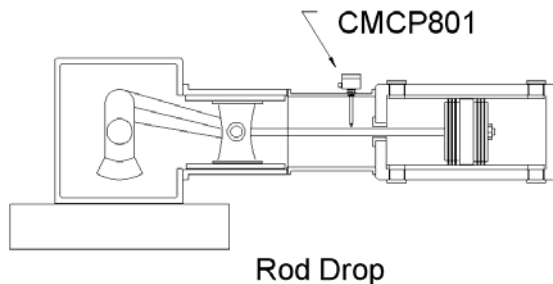

To measure Rod Drop with an Eddy Probe system, the probe is installed in the vertical direction viewing the rod. The preferred installation would have a probe bracket adapted to the packing gland plate, mounted internal to the distance piece. As an alternate solution, some users have used the CMCP801 Eddy Probe Housing, providing an external adjustment (through the distance piece) of the probe gap. As the Eddy Current field emitted from the probe tip will penetrate the rod surface 15 mils, it is important that the observed rod be homogenous in nature and free of any surface irregularities. The Eddy Probe system is interfaced to a CMCP545 Position Transmitter to measure the probes DC output (Probe Gap). The CMCP545 will provide a 4-20 mA output that is proportional to the DC Gap Voltage. If a CMCP545A Monitor is used, two levels of alarms with corresponding Alert and Danger relays are provided. By trending the DC Gap voltages from the eddy probe, it is possible to measure the average horizontal running position of the piston rod. This method of Rod Drop measurement offers advantages over the previously described methods:

1. An immediate trend of ring wear can be established.
2. The periodic inspections that require a machine shutdown and disassembly are eliminated.
3. Wear rate changes can be observed.
4. Both Warning and Shutdown alarms can be provided.

## Reciprocating Compressors

## Recip

Monitoring the Rod Drop of a Reciprocating Machine using an Eddy Probe offers the following benefits:

1. Prevents Cylinder and Piston damage caused by the Piston contacting the liner.
2. Stops unnecessary periodic inspections that require a machine shutdown with the associated lost process time.
3. Scheduling down time to replace or rotate wear rings within the limitations of a plant's schedule.

### Rod Run Out

Whereas Rod Drop is a measurement of rod position, Rod Run Out is a measurement of the rod's actual dynamic motion as it travels back and forth on its stroke. Another term for this measurement is Rod Deflection.

One method to make this measurement is to mount a dial indicator in the distance piece riding on the piston rod. The machine is then barred through a complete cycle. Indicator readings are taken in both the vertical and horizontal directions during the machine's cycle.

The amount of Rod Run Out is highly dependent on the cylinder alignment with the Crosshead. Due to inherent looseness in the Crosshead and thermal growth of the machine, higher readings of Rod Run Out are allowed in the vertical direction. The horizontal direction allowances are much less and high readings are attributed to misalignment. Typical Rod Run Out allowances are 3.5 to 6.0 mils Pk-Pk in the vertical direction and 1.5 to 2.0 mils Pk-Pk in the horizontal direction.

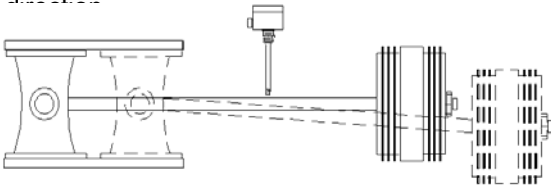

Rod Run Out

An alternative to dial indicators to make this measurement is again an Eddy Probe System. Since dial indicators can only be used while the machine is being barred, they do not provide an accurate measurement of Rod Run Out. On the other hand, Eddy Probes can make this measurement while the machine is operating. This provides a highly accurate measurement of the actual dynamic motion of the rod under full load conditions.

5 Eddy Probes for Rod Run Out measurement are typically used on "Hyper Compressors". These are reciprocating compressors used for very high compression ratios up to 60,000 PSI discharge pressure. To withstand the high pressures, the gland seals on these machines are quite complex and small amounts of Rod Run Out will cause these gland seals to fail with severe consequences.

Hyper Compressor Piston Rods are manufactured of Tungsten Carbide. Tungsten Carbide is a very hard material (Rockwell C values of approximately 84): will handle enormous compressive loads, but is much weaker when subjected to tension of flexing. Either a gland seal or Piston Rod failure in a Hyper Compressor will have harsh consequences.

Utilizing the AC component (dynamic motion) of an Eddy Probe signal, one eddy probe is mounted in the vertical (x) axis and one is mounted in the horizontal (Y) axis in relation to the Piston Rod. Each Eddy Probe is interfaced to a CMCP540A Vibration (Displacement) Monitor for signal conditioning, alarming and interface to a PLC or DCS.

The vertical Eddy Probe can also be used as for Rod Drop measurements. Therefore, the installation of X and Y Eddy Probes can be used for both Rod Run Out and Rod Drop measurements.

This method of Rod Run Out measurement offers advantages over the dial indicator method:

1. The measurement is taken all the time.
2. The measurement is taken while the machine is operating under load and at temperature.
3. Alarms are provided for early indication of problems and machine shutdown if desired.

## Reciprocating Compressors

Recip

Monitoring the Rod Run Out of a Reciprocating Machine using X, Y Eddy Probes offers the following benefits:

1. An assurance that Rod Run Out is within tolerable limits after the machine is at operating speed and temperature.
2. An early warning of gland seal failure caused by excessive Rod Run Out.
3. Machine shutdowns for repairs can be scheduled to reduce effects on plant production.

## Crosshead Vibration

The Crosshead of a Reciprocating Machine is made up of several major components: Crosshead Bed, Crosshead, Slippers and Crosshead Pin. The purpose of the Crosshead is to transform the circular motion of the crankshaft into linear motion for the rod and piston.

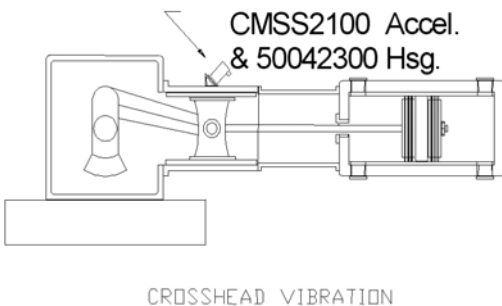

The Crosshead slides on a lubricated babbitted surface much like a standard journal bearing. However, the Crosshead slides back and forth instead of in a circular motion like a shaft. Clearance between the Crosshead and the babbitt surface may be in the range of 10 to 25 mils. As crankshaft rotates, the Crosshead is driven to slide on either the upper or lower babbitt surface. As the clearance between the Crosshead and babbitt surface increases, the Crosshead vibration increases.

In a compromise to measuring both vertical and in-line with the cylinder, experience has shown that a 786A Industrial Accelerometer, mounted on a 45° angle block, located in-line with the piston travel, will adequately measure Cross Head vibration. The 786A Accelerometer would be connected to a CMCP530(A) Velocity Transmitter (Monitor).

By processing the vibration signal in Peak Acceleration instead of RMS detection, we can measure high amplitude short duration "peals" or "events" that appear periodically. The Cross Head mounting location in-line with Piston travel will see the mechanical transfer of energy caused by impacts resulting from mechanical looseness on the compressor cylinders, such as loose rod nuts and loose bolts. Liquid in the process can also be detected. Competitive offerings may refer to this measu

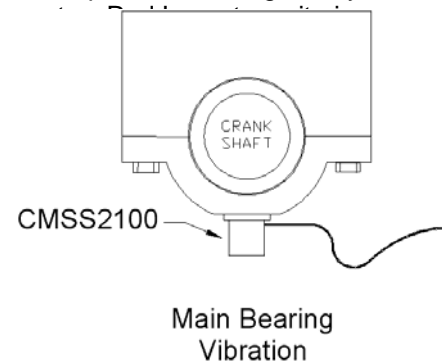

Crosshead Pin lubrication can also be diagnosed with this measurement. The Crosshead Pin connects the connecting rod from the crankshaft to the crosshead. This pin is force lubricated through "reversal" which allows oil between the pin and its bushing. With each stroke, the oil is forced out. If reversal does not occur, the pin and its bushing will fail rapidly.

Monitoring the Crosshead Vibration with an Accelerometer offers the following benefits:

1. Assures that the Crosshead to babbitt surface clearance is within acceptable limits.
2. By analyzing the vibration waveform, Crosshead Pin reversal can be confirmed.
3. Machine shutdowns for repair can be scheduled.

### Main Bearing Vibration

Main Bearing Vibration has not been proven to be a popular approach for monitoring Reciprocating Compressors. Several end users have had problems with broken crankshafts, which they thought were caused by unusual bending of the crankshaft. In one documented case, machinists had over tightened the drive belts powering the cooling fan on a reciprocating engine. This caused unnecessary bending of the crankshaft.

Currently, several end user's have installed X and Y Eddy Probe systems on the main bearings of large 12,000 HP Reciprocating Compressors. This installation very nearly resembles that of a standard centrifugal compressor. However, both probes view the crankshaft from the bottom bearing cap-mounted 90° apart. As the lubricating oil cools the main bearing, no unusual measures needed to be taken on this installation.

6  
The Eddy Probes are connected to a CMCP540 Vibration (Displacement) Monitor to measure radial vibration. The full-scale range of the monitor is based on the bearing clearance. As in all Reciprocating Compressor applications, the entire bearing clearances are used.

A cost effective compromise in lieu of installing X, Y Eddy Probes is to mount a CMSS2100 Industrial Accelerometer in-line with the crankshaft centerline and interface it with a CMCP530(A) Velocity Transmitter (Monitor).

### Valve Temperature

According to industry studies, valve failures account for 41% of the problems associated with reciprocating machinery.

In a Reciprocating Compressor, the valves are a pressure actuated "Poppet" variety. Every machine manufacturer has favorite types of valves for different applications. These valves operate utilizing a delta or differential pressure technique. The opening and closing of a valve occurs when the delta pressure is less than the force of their return springs.

When a valve begins to fail, it usually begins to leak the process gas. This causes the process gas to be re-compressed, further heating the gas. This higher temperature process gas can be detected using a temperature transducer. This transducer can be mounted through the valve cover plate measuring the gas temperature near the valve. In some installations, the transducer is simply imbedded in the valve cover plate, or within a valve cover plate bolt. This mounting method is preferred when the process gas is explosive, which is usually the case.

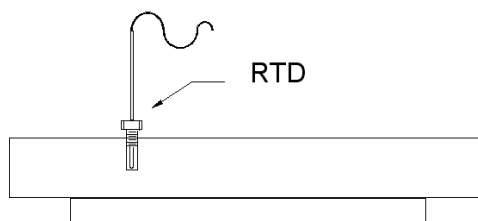

Valve Cover  
Temperature

The measured temperature of the process gas is then compared to the measured temperature of the process gas at the same type valve, suction or discharge, and the same stage of compression. Measured temperature differences of 4 to 20° F can indicate a problem with a valve.

Monitoring the temperature of the process gas at each valve offers the following benefits to the customer:

1. Provides an early indication of a problem with a valve reducing the possibility of machine damage.
2. If a problem with a valve occurs, only the bad valve needs replacement increasing machine run time. This approach does not limit the life of all the valves to the shortest life of a valve.
3. Trending the valves' conditions can allow for scheduled machine shutdowns.
4. Help prevent damage to the cylinder lining that occurs when valve parts are ingested by the machine.
5. Each RTD is connected to a CMCP560(A) RTD Temperature Transmitter (Monitor).



# Field Application Note

Reciprocating Compressors

Recip

## Checklist

1. Target Material (Rod Drop & Run Out)
2. Rod Drop Full Scale Range
3. Machine Speed/Low Frequency Transducers
4. Transducers Mechanically Protected
5. Flexible Conduit (J-Box to Transducer)
6. IMC Conduit (J-Box to Monitor)
7. Correct Instrument Wire
8. Instrument Wire Shielding Conventions
9. Calibration
10. Eddy Probe Gap Set
11. CMCP500 Series Monitors