

## Turbine Supervisory Instrumentation

## Part 2-Valve Position

Valve position measurements are an important aspect of a complete Turbine Supervisory Instrumentation system. Typically, the Main Steam Control (or Throttle) Valve is always included in the system with other valves added depending upon the control system incorporated in the turbine design. Addition of a position transducer to a hand wheel operated throttle valve, which was equipped only with a graduated scale for indication, will allow more precision in valve positioning.

Valve position indication is actually a measurement of the amount a valve is closed or open. This measurement is usually made with a Linear Variable Differential Transformer (LVDT), but sometimes a Rotary

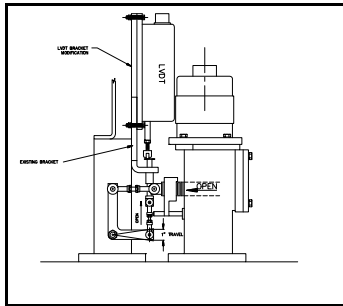

Potentiometer is used for special applications. Nearly all applications require bracket made to attach the transducer and another bracket in physical contact with the moveable portion of the valve (stem or linkage).

### Theory of Operation

#### LVDT

LVDTs are electromagnetic devices that have three coils of wire wound on a hollow tube and a metal rod moving inside the hollow tube. The center coil of wire is excited by a supply voltage, which induces a voltage in the other coils as the rod, or plunger

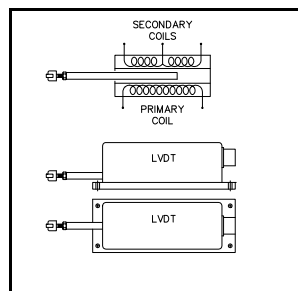

For valves having longer strokes (greater than 2

travels throughout its range.

When the plunger is centered in its range the induced voltage of the two secondary coils is equal in magnitude, but opposite polarity. As the plunger moves to either side of the center position the voltage of one of the secondary coils increases while the other secondary coil experiences a decreased voltage. DC LVDT's differ from AC LVDT's in that they are manufactured with an internal carrier generator/signal-conditioning module and only require DC Power to operate.

#### Rotary Potentiometer

The rotary potentiometer is a device very similar to a variable resistor. It has a coil of wire shaped in an arc with a wiper, which moves across the wire coil. As the wiper, which is attached to the valve camshaft, moves across the coil of wire a differing voltage is output proportional to the angle at which the wiper is located.

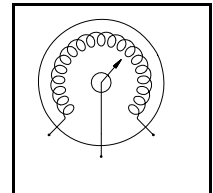

### Special Considerations

#### Operating Range

The SKF-CM line of LVDT's, P/N# CMSS51A have a range of 1, 2 and 4" with an accuracy of  $\pm 0.5\%$  full scale. A shorter range may be selected by using the center portion of the standard operating range.

SKF-CM's rotary potentiometer P/N# CMSS30503100 is a direct replacement for GE Catalog No. 9888323 or equivalent.

#### Transducer Installation

The body of the LVDT is designed to be rigidly attached to an immovable location or bracket with the rod pressing against the valve stem or bracket. Proper installation of the LVDT involves selecting a location where the operating range is not exceeded and the LVDT rod has free travel.

inches), a suitable location along the valve

operating linkage must be selected where the LVDT operating range is not exceeded. An alternative is to design a custom linkage to achieve the range required. A second alternative is to install a circular cam to the throttle valve cam assembly and install the LVDT so that the rod contacts the cam. The latter alternative is not applicable on smaller turbines, which may not have a throttle valve manifold containing several steam valves intended to open at differing loads.

Rotary potentiometers, by their design, require that they be installed at the end of the throttle valve camshaft or valve linkage axle. The valve axle shaft will require modification to allow the potentiometer shaft to be clamped rigidly, possibly with a coupling. The potentiometer body must be installed so that it will not rotate as the valve shaft rotates.

### Conduit

Dedicated conduit should be provided in all installations for mechanical protection of the instrument cable. Rigid conduit is required from the monitor location to the LVDT or Potentiometer location. The final 2-3 feet of the conduit installation should be completed with flexible conduit to allow transducer removal.

### Measurement Convention

Measurement convention involves determining which direction the valve operates in relation to the selected transducer location. The SKF-CM LVDT rod is spring loaded with the rod forced in the extended direction. The standard installation has the extended orientation representing 0% indication or valve closed and the fully compressed orientation representing 100% indication or valve fully open.

Many times the LVDT cannot be installed in the standard configuration and orientation due to space considerations or other circumstances. This situation should not preclude the installation because the output signal can be electrically inverted at the monitor location.

Rotary potentiometer applications follow the same measurement convention argument as LVDT installations.

### Instrument Wire

For LVDT and Rotary Potentiometer applications a 3-wire twisted shielded instrument wire should be utilized between the monitor location and the LVDT. This wire should be a continuous run and

not be spliced.

The following table is a partial list of Belden® Cables that should be used for the instrument wire.

These part numbers may be cross-referenced to equivalent cables from other manufacturers. The listed cables are polyethylene insulated, twisted, with Beldfoil shield, drain wire, and PVC jacket.

Belden® Part Numbers (LVDT)

	<u>PN</u>	<u>Nom. O.D.</u>
18 AWG	8760	0.22"
20 AWG	8762	0.20"
22 AWG	8761	0.18"

### Calibration

The LVDT is designed to be installed so that when the rod is positioned in the center of its operating range the LVDT output voltage should be 0 VDC. This calibration may be accomplished by temporarily inserting a 1.0" block under the rod and adjusting the roller tip, located at the end of the rod, until 0 VDC is obtained at the transducer output. As the valve is stroked throughout its full range, the LVDT output voltage should be noted for monitor re-calibration.

Rotary potentiometers are installed so that the potentiometer shaft is attached to the camshaft or other rotating shaft with the potentiometer body rigidly held so it does not rotate. The potentiometer should be adjusted so that when the rotation angle is 0° the signal output should be 0 VDC. As the valve is stroked throughout its full range, the output voltage should be noted for monitor re-calibration.

### Valve Position Checklist

1. Xdcr Type, LVDT " Rotary Pot. "
2. Operating Range "
3. Transducer Location(s) "
4. Measurement Convention "
5. Xdcr Installation Documented "
6. Correct Instrument Wire "
7. Flexible Conduit "
8. Calibration "