





# OPERATION MANUAL

## Position Input Transmitters and Monitors

CMCP545(A)

 <p>Hazardous Location Safety E112798 UL1604, CSA C22.2 No 213 C1, Div 2, Grp B,C,D 24 VDC, 50 mA Max</p>	<p><b>NOTICE!</b> This equipment is suitable for use in Class I, Division 2, Groups B-D</p>	
--	---	---

**IMPORTANT!**  
After installation of this unit, no connections are to  
be made or broken while any connection on the unit is powered up.

# Table of Contents

- 1.0 General:**
  - 1.1 Model Description
  - 1.2 Power
  - 1.3 Opening the Case
  - 1.4 Dimensions and Mounting
- 2.0 Transmitter:**
  - 2.1 Transducer
  - 2.2 Transducer Cable
  - 2.3 Transducer OK Circuit
  - 2.4 Full Scale Range
  - 2.5 4-20 mA Output
  - 2.6 Buffered Output
  - 2.7 Transmitter Jumper Selection
  - 2.8 Offset
- 3.0 Monitor Alarm Module:**
  - 3.1 Alert and Danger Setpoints
  - 3.2 Alert and Danger Delay Adjustment
  - 3.3 Latching/Non-Latching Alarms
  - 3.4 Trip Multiply
  - 3.5 Alarm Relays
  - 3.6 Alarm Module Jumper Selection
- 4.0 Test and Calibration Setup:**
  - 4.1 Test Setup
  - 4.2 Calibration

## 1.0 General

### 1.1 Model Description:

The **CMCP545** is a 4-20mA Position Transmitter. It is typically used in conjunction with an eddy current probe/driver system, and an external readout/monitoring system, to indicate the relative axial position of a rotor within its associated thrust bearing range. In this application, it is recommended that two independent probe/driver/transmitter channels be installed to provide redundancy, and to allow the readout/monitoring system to perform logical comparisons of the thrust readings from each channel prior to taking action on any single alarm condition.

Although the CMCP545 operates from a +24Vdc supply, it is compatible with most non-contact eddy-current probe/driver systems that operate from a -24Vdc supply. (-18Vdc probe/driver systems can also be made to work. Contact the factory for details). The output signal from the probe driver is processed to determine the relative position of the target with respect to the face of the probe. The transmitter output is a standard 4-20mA current proportional to this position within a specified full scale range such as 40-0-40 mils, and is suitable for direct connection to a PLC or DCS monitoring system. A BNC connector on the front of the unit provides buffered access to the probe driver voltage to assist in probe setup.

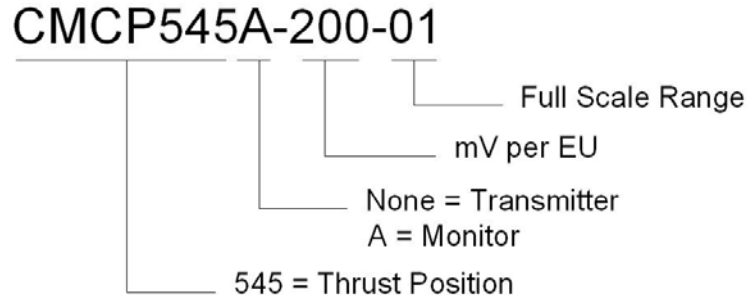

### 1.2 Power:

The CMCP545 requires externally supplied DC power. The power supply should have a nominal output of +24Vdc and be capable of supplying a minimum of 50mA for transmitters or 100mA for each monitor in the system. A +24Vdc power-supply dedicated to the vibration monitoring system is recommended.

The associated eddy probe/driver system will require an additional -24Vdc supply. This supply should be located next to the +24Vdc supply and have its common side tied to the common side of the +24Vdc supply used for the transmitters. It is recommended that the connection between the power-supply and the transmitters and probe-drivers be made using twisted-shielded instrument cable. The cable shield should float at the transmitter / driver, and be connected to common at the power-supply / system-common end only.

The CMCP545 regulates dc power internally to prevent a fault on the output of one channel from affecting other channels. When power is first applied to the transmitter after connecting the transducer, there will be a delay of approximately 30 seconds before the "OK" LED turns "ON".

### 1.3 Opening the Case:

Opening the case is best done with a small flat-blade screwdriver. On transmitters (1" wide units) insert the tip of the screwdriver between the right-side cover (as viewed from the front of the unit) and the DIN rail mounting foot at the back of the unit and gently leverage the blade to begin separating the cover from the rest of the unit. Carefully work your way around to the front of the unit to complete removal of the cover, exposing the circuit board components. On Monitors (1.6" wide units), you must first CAREFULLY separate the two halves of the unit at the center. The sides do not need to be removed. This is done by working the

screwdriver around the middle of the unit in the same general manner described above. As the two halves start to become separated, you will see that they are still attached by a short ribbon cable inside. This cable can be carefully removed by pulling it away from the left hand side of the unit. The cable stays with the right hand side permanently. **CAUTION:** When re-installing this cable, make sure it is properly connected to the mating connector, and that the bend in the cable goes towards the front panel side of the unit. IF THE UNIT IS CLOSED WITH THE BEND TOWARDS THE BACK, THE RIBBON CABLE CAN BE DAMAGED. Also, make sure the ribbon cables' connector does not catch on the relays when pressing the unit back together.

## 1.4 Dimensions and Mounting:

CMCP500 Series Transmitters and Monitors are designed to be mounted on Din Standard 35 mm "T" Rail or "G" Rail. They simply snap in place by aligning the top of the mount on the track and pressing down. To remove insert a screwdriver in the tab at the bottom and pull down and out slightly.

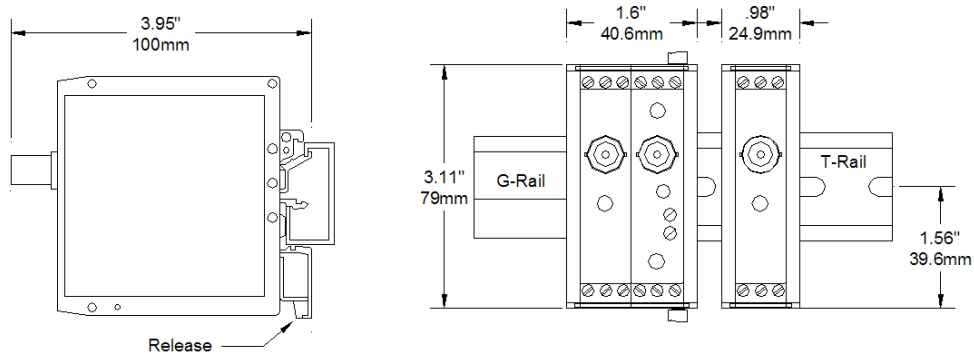

## 2.0 Transmitter

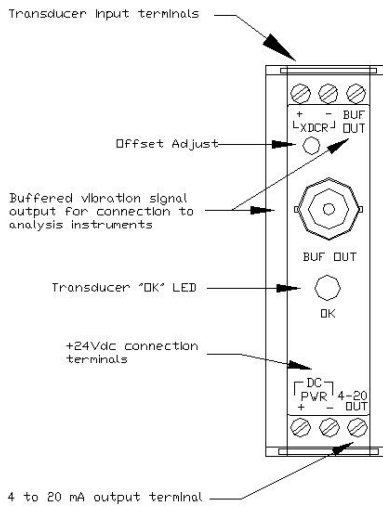

### 2.1 Transducer:

The CMCP545 is factory configured for use with an eddy-current probe-driver system. The specific sensitivity in mV/mil is identified by a dash number immediately following the basic P.N. on the side label. Example: "-200" indicates the transmitter expects the associated probe driver to have an output sensitivity of 200mV/mil. Other sensitivities than indicated here are available.

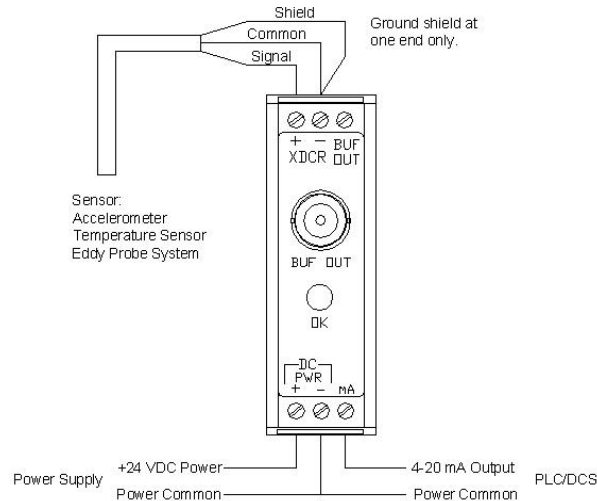

## 2.2 Transducer Cable:

It is strongly recommended that the transmitter be mounted as close as practical to the associated probe driver. This will help to minimize interference from external noise sources. A twisted shielded, properly installed cable from the probe driver to the transmitter is necessary to obtain reliable operation. The cable shield should be open at the probe driver, and connected to common (xdcr "-" terminal) at the monitor/transmitter input only. The cable should be routed as far away from other electrical circuits as possible, and routed through metal conduit where necessary to minimize noise pickup.

## 2.3 Transducer OK Circuit:

The CMCP545 incorporates a transducer "OK" circuit. This feature continuously monitors the probe-system output voltage. If this voltage exceeds preset "OK" limits, the 4-20 mA output current is reduced to less than 2 mA (typically 0 mA) to allow detection of the fault condition at the associated monitoring system. A Green "OK" LED on the front of the unit (normally "ON" in an "OK" condition) turns "OFF" to provide a local indication of the fault condition. This circuit will effectively detect open, shorted, or reversed transducer connections. If a fault is detected and then subsequently removed, there will be a delay of approximately 30 seconds before the unit returns to the "OK" condition and the "OK" LED turns back "ON".

## 2.4 Full Scale Range:

The CMCP545 Series is supplied factory calibrated for the full-scale range specified at the time of order. Other ranges may be implemented (see table below) by changing the positions of internal jumpers as indicated in the table below. See "Opening the case" to gain access to these jumpers. Changing range jumpers without further re-calibration will introduce an additional reading error of 2% maximum. For greater accuracy the unit must be re-calibrated. (See Section 2.8: "Transmitter Jumper Settings") The factory calibrated range is listed on the side label as a dash number. Custom ranges are available.

Range	CMCP545
-01	+/- 20 mils (+/- 0.51 mm)
-02	+/- 40 mils (+/- 10.2 mm)
-03	0-40 mils (0-10.2 mm)
-04	0-80 mils (0-20.3 mm)

## 2.5 4-20 mA Output:

The output of the transmitter is 4-20 mA current which is proportional to the zero-to-full-scale range of the unit. IE: If the range is 40-0-40 mils, then 4mA corresponds to -40.0 mils, 12mA corresponds to 0 mils, and

20mA corresponds to +40.0 mils. This output will drive a maximum resistive load of 500 Ohms with respect to system common however; the recommended load is a precision 250 Ohm resistor. This will convert the 4-20mA current to 1-5Vdc at the control/monitor system input. A continuous short to ground (common) on the 4-20 output will not damage it.

## 2.6 Buffered Output:

The CMCP545 provides buffered access to probe driver output voltage via a BNC connector on the front of the unit. This output has the same sensitivity and units as the transducer itself, i.e.: the same mv/mil. However, the voltage at this output is the opposite polarity of the probe driver output, so a probe driver output voltage of -10.0 Vdc will read as +10.0 Vdc on a digital voltmeter at the buffered output. This output is also available on a screw terminal at the top of the unit.

## 2.7 Transmitter Jumper Selection:

The CMCP545 comes factory set calibrated to the full-scale range specified at the time of order.

### Option: Range:

-01	20-0-20 mils (+/- 0.51 mm)
-02	40-0-40 mils (+/- 10.2 mm)
-03	0-40 mils (0-10.2 mm)
-04	0-80 mils (0-20.3 mm)

The factory calibrated range is listed on the side label as a dash number. If a range other than shown above is indicated, the unit has been modified or adjusted for a special range.

## 2.8 Offset

The CMCP545 Position Transmitter is supplied with an "Offset" adjustment potentiometer located just below the transducer input terminal (top left of the front faceplate). The Offset adjustment can be used to adjust the center of the mA output (12 mA) to match the DC gap voltage that corresponds to the center or the active shoe, depending on which method is used. Care should be used to insure that the full 4-20 mA output always remains within the linear range of the sensor system. For further information see STI's Thrust Position Application Note available online at [www.stiweb.com](http://www.stiweb.com). The Offset is initially factory adjusted so that 10.0 VDC corresponds to an output of 12 mA.

## 3.0 Monitor Alarm Module (If Equipped):

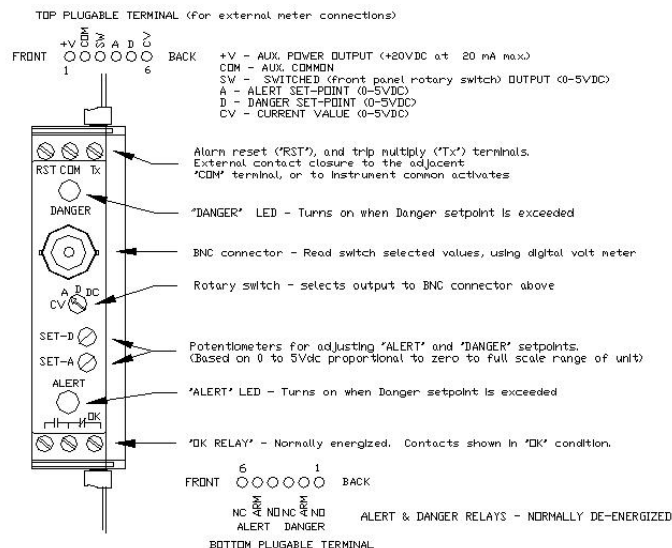

### 3.1 Alert and Danger Alarm Set-Point Adjustment:

The Alert and Danger alarm set-points can be independently set in the field by turning the front panel selector switch to the associated position (A or D) and adjusting the associated front-panel potentiometer until the correct DC voltage is measured at the BNC connector located directly above the selector switch. Adjusting the set-point requires the use of a digital volt-meter, knowledge of the full scale range of the monitor, and the desired set-point as a percentage of the full scale range. The voltage measured at the BNC will vary between 0 Vdc and 5 Vdc, corresponding to 0 to Full-scale. i.e.: 2.5 Vdc represents 50% of full scale, 3.75 Vdc represents 75% of full scale. To calculate the required set point voltage if the unit is not equipped with a display, use the equation,  $5(.xx)$  where .xx is the desired percentage expressed as a decimal fraction of the full scale range. i.e.:  $5(.60) = 3.00$  Vdc for a set-point of 60% of the full scale range. Turning the potentiometer clockwise increases the set point voltage.

### 3.2 Alert and Danger Alarm Delay Adjustment:

The Alert and Danger alarm delays can be independently set by internal jumper selection to 0.1, 1.0, 3.0, 6.0, or 10.0 seconds. The purpose of the delay is to reduce nuisance alarms caused by external electrical noise and/or transient vibration events. Both the Alert and Danger delay are factory set to the 3 second position. To change the delay, open the unit and move the delay jumpers to the proper position (Refer to Section 3.6 "Alarm Module Jumper Settings").

### 3.3 Latching/Non-Latching Alarms:

The Alert and Danger alarms are factory set for NON-LATCHING operation. This means that whenever the vibration level drops below the associated set-point for more than about 1 second, the associated relay will de-energize and the alarm LED will turn off. The alarms can also be set for LATCHING operation by installing shunts on jumpers E1 and E2 respectively on the Alarm module circuit board (See: CMCP500 SERIES ALARM MODULE JUMPER LOCATIONS, at the back of this manual). Latched alarms may be reset by closing the RESET (RST) and COMMON (COM) contacts at the top of the unit. This may be done with an external switch, dry contact relay, or by shorting the terminals together by hand. **DO NOT APPLY VOLTAGE TO EITHER THE "RST" or "COM" TERMINALS.** If several monitors are mounted together, the "RST" terminals may be daisy-chained together.

### 3.4 Trip Multiply:

The alarm module provides a trip multiply feature. This feature allows the user to temporarily double (standard) or triple (jumper selectable) the normal set points during periods of normal high vibration such as start-ups. To actuate the trip multiply feature, the Tx terminal at the top of the alarm module must be closed to the adjacent "COM" terminal. This may be done with an external switch, dry contact relay, or by shorting the terminals together by hand. **DO NOT APPLY VOLTAGE TO EITHER THE "Tx" or "COM" TERMINALS.** If several monitors are mounted together, the "Tx" terminals may be daisy-chained together and switched to "COM" (system common) as a group.

### 3.5 Alarm Relays:

The Alert Danger and OK relays are independent, single-pole-double throw relays. NO, ARM, and NC contacts are available via plugable screw-connector at the bottom of the monitor. OK relay contacts are available on fixed screw terminals at the bottom front of the alarm module (Refer to Section 3.0 "Monitor Alarm Module"). Relay contacts are rated 5 Amps at 30 Vdc or 125 Vac, resistive load. This rating includes any inrush current that the load draws. For loads that are not purely resistive the contact switching capability will need to be considered carefully in terms of this inrush current. The entire subject of relay application is too large to address here, so the user is cautioned to use care in the application of the relays. The factory intended purpose of providing relay contacts is to operate relatively low power alarm annunciators, act as a dry or low dc voltage contact closure input to other systems, or act to actuate an appropriately sized slave relay for larger loads such as shutting down a motor. Relays are socketed and can be replaced.

### 3.6 Alarm Module Jumper Selection:

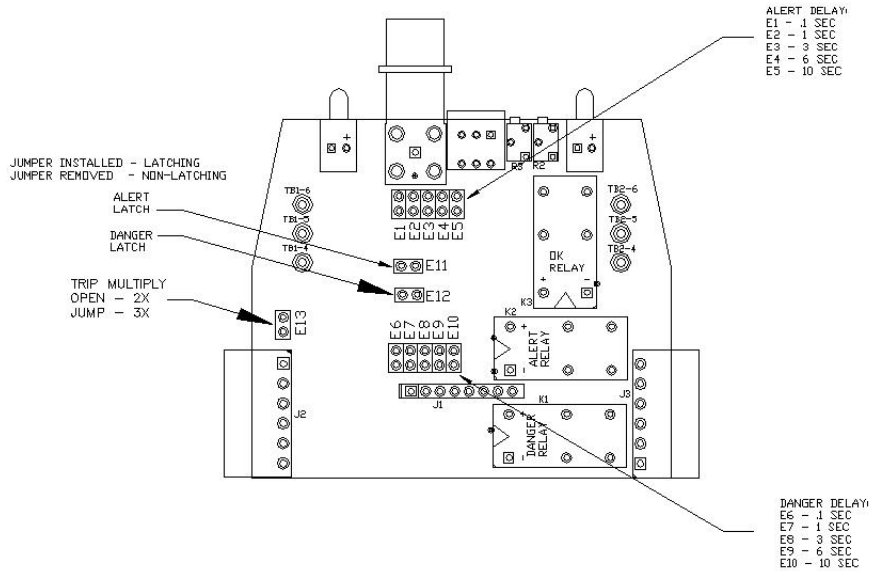

## 4.0 Test and Calibration:

### 4.1 Test Setup

The test equipment listed below is required to perform calibration:

- (1) +24 Vdc linear regulated power supply
- (1) Variable DC power supply with floating output (for simulating BOV).
- (2) 4.5 digit DC/True RMS reading digital volt/current meter. Fluke 87 or better

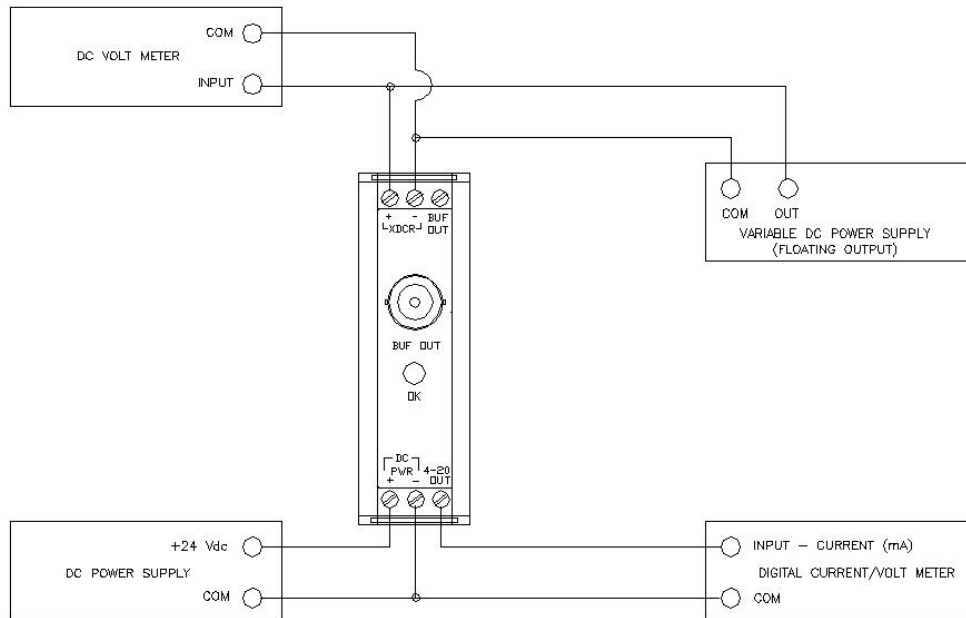

## 4.2 Calibration:

The CMCP545 is factory configured for the full-scale range indicated on the side label. The midscale (12.00 mA) output has been factory set to correspond to an input voltage of -10.00 Vdc. One method of performing the initial system setup is to force the machine to the actual thrust position that is intended to be the mid-scale point, and then mechanically adjust the probe gap so that the probe-driver output voltage is -10.00Vdc at this point. If the probe cannot be accessed for adjustment, or if the only **known position** the machine can be placed in is different from the mid-point, the offset (zero) potentiometer on the front of the transmitter can be adjusted within a limited range to match this known thrust-position as follows:

**Note: This does not change total available range, so shifting the mid-point will create an Asymmetrical range such as 20-0-60 on a 80 mil total range transmitter.**

1. Measure the actual output voltage of the probe-driver with the machine at a **known thrust position** within the allowable thrust range, and calculate the output current that corresponds to this position within the specified full-scale range of the transmitter. **Note: It is imperative that the installed probe/driver have the appropriate sensitivity and range to cover the necessary mechanical thrust range while staying within driver output voltage limits of -2Vdc to -18Vdc.**
2. Apply the negative voltage determined in step 1, to the transmitter "+" input. This voltage can be from the actual probe-driver output or an external -Vdc supply.
3. Monitor the transmitter output current and if necessary, adjust the "Offset" potentiometer (unmarked but located just below the "XDCR" input terminals at the top of the unit) until the output current corresponds to the calculated reading for the known thrust position within the total range specified for the transmitter. NOTE: The CMCP545 is factory configured so that target motion towards the probe-face (probe driver output voltage going **towards zero volts**) will cause the output current to move upscale (towards 20.0 mA).